



DL2000

User's Guide

Revision 1.01 – April 21, 2004

Equustek Solutions, Inc.
Suite 815, 1200 W73rd Ave.
Vancouver, BC, Canada
V6P 6G5
Toll Free: 888-387-3787
<http://www.equustek.com>

Table of Contents

1.0 DL2000 General Operation & Applications	3
2.0 Hardware Specifications	4
2.1 Operating Specifications:	4
2.2 Physical Specifications:	4
3.0 DL2000-Hardware Layout	5
3.1 Front Panel	5
3.2 Rear Panel	5
4.0 Mode of Operation	6
4.1 Online Mode of Operation	6
4.2 Offline Mode	6
4.3 OFF-LINE Flash Manager Options	7
5.0 Switch and LED Indicator Functions	8
5.1 Switch Functions	8
5.2 Indicator Functions	8
5.2.1 Power-Up and Reset Sequence	8
5.2.2 Normal On-line Operation	9
5.2.3 On-Line, Power-Up and Reset Errors	9
5.2.4 Off-Line Modes	9
6.0 DL2000 Wiring Diagrams and Jumpers	10
6.1 Input Voltage Selection	10
6.1.1 AC Voltage selection	10
6.1.2 DC Voltage selection	10
6.2 Port B' Connector (CHB) Internal Jumpers	10
6.3 Online Cable DL2000-PORT A DH+ (CHA)	10
6.4 Configuration Cable/Online Cable DL2000-Port B (CHB) RS-232 – No Handshaking	11
6.5 Online Cable DL2000-Port B (CHB) RS-232C – With Handshaking	11
6.6 Online Cable DL2000-Port B (CHB) RS422/RS485	11
6.7 Online Cable DL2000-Port B (CHC) RS232	11
6.8 Online Cable DL2000-Port B (CHC) RS422/RS485	12
6.9 Online Cable DL2000-Port B' (CHB) RS232	12
6.10 Online Cable DL2000-Port B' (CHB) RS422/RS485	12
7.0 DL2000 DH+ Networking Applications	13
7.1 DL2000-CMX – Modbus Master/Slave to interface to DH+	13
7.1.1 Modbus Master Mode	13
7.1.2 Modbus Master Mode using MODBUS PLUS VIA BM85 BRIDGE	13
7.2 DL2000-KFX – DF1 to DH+ interface	14
7.3 DL2000-ASM – DH+ to ASCII Scanner/Printer interface	14

1.0 DL2000 General Operation & Applications

The DL2000 communication controller is a 110/220V AC powered freestanding CSA/UL approved which provides a RS232/RS422/RS485 serial link to A-B's DH+ or RIO networks.

The DL2000 has two communication ports. Channel A is designed to connect to your industrial network, either A-B's DH+ or RIO networks. Channel B is used to connect to your serial device, such as PC's, HMI/MMI's or PLC's. The protocol used depends on which flavour (model) of the DL2000 you have ordered.

Channel B has the capabilities of RS232C, RS422, and RS485.

Configuration of the operating parameters is done quickly and easily by the DL32-FREEstanding windows based software shipped with the unit or available on the Equustek [Website](#).

Currently there are three standard DL2000 products available to allow access to A-B's DH+ network; also many other customized ASCII protocol interfaces have been done. Contact Equustek Solutions to see if the DL2000 is the correct device for your communication needs.

The **DH+ version** of the DL2000 product line is as follows:

The **DL2000-CMX** is a two port device that bridges your Modicon Modbus devices to ones on a DH+ network. The Modbus model can either be used as Modbus Master or Slave as well as having both Modbus ASCII and RTU protocols.

The **DL2000-KFX** is a two port device that allows your DF1 devices (either Full or Half Duplex protocols) to ones on a DH+ network. The DF1 model is a direct replacement for the 1770-KF2 and allows your PCs or Laptops access to any node on the DH+ network.

The **DL2000-ASM** interfaces Serial ASCII devices (Scanners/Printers) to SLC's or other devices on A-B's DH+ network.

2.0 Hardware Specifications

The DL2000 Hardware Platform has the following specifications.

2.1 Operating Specifications:

CHA can be configured for DH+/RIO speeds of 57.6, 115.2 and 230.4 KBaud.

CHB has full RS232C, as well as both RS422 4 wire and RS485 2 wire modes. CHB has the ability of being configured with asynchronous speeds upto 57.6 KBaud. CHB has two physical connections, a DB 25 Male and a configurable 5 pin phoenix (jumper configurable for RS232/RS422-RS485).

Currently industry standard protocols of DF1, Modbus, and ASCII are the supported. Many custom protocols for different Variable Speed Drives, Weight Scales and other OEM devices have been implemented. Both CRC 16 and BCC error checking can be implemented; custom error checking can be added at the customer's request.

Simple Parameter Configuration using menu driven Windows (95/98/ME/XP/NT/2000) based Program via RS-232 Cable.

Configuration and Reset Pushbuttons to setup online configuration parameters and do a full Hardware Reset

Operating Parameters are stored in Non-Volatile Serial EEPROM

The DL2000 uses FLASH upgradeable firmware from the configuration Software.

Green communication LED's for each communication channel indicates activity and status.
Red ERR Led indicates communication problems
Green POWER LED indicates power on.

2.2 Physical Specifications:

Dimensions: 1.5" H x 7.5" L x 5.5" W (3.8 x 19.1 x 14 mm) - Weight 2.2 Lbs (1.0 Kg)

Installation: Metal Enclosure; Desktop

Operating Environment: 32 to 122 °F (0 to 50 °C)

Storage: -40 to 185°F (-40 to 85°C)

Humidity: 5% to 95% non-condensing

Power: 110 VAC 60Hz +/- 25 %, 5W, 220 VAC 50Hz +/- 25 %, 5W, 10 to 35 VDC, 5W

3.0 DL2000-Hardware Layout

This Section contains information of the physical position and purpose of the components of the DL2000.



3.1 Front Panel

The FRONT panel contains the following. Going left to right.

- 25 pin DB25M PORT B connector for asynchronous communications (CHB)
- 2 green CHAN 1 LEDs indicate the status of CHA (DH+/RIO)
- 2 green CHAN 2 LEDs indicate the status of PORT B (CHB-Asynchronous)
- Red ERR LED which indicates communication problems
- Green POWER LED indicates supply power

3.2 Rear Panel

The REAR panel contains the following. Going left to right.

- RESET Pushbutton does a full system reset to put the unit on-line
- CFG (Configure) Pushbutton puts the unit into the off-line manager mode
- PORT A (CHA-DH+ or RIO) 3 pin Screw terminal (Phoenix Type)
- PORT B' (CHB-Asynchronous) 5 pin Screw terminal (Phoenix Type)

4.0 Mode of Operation

4.1 Online Mode of Operation

Online Mode is the normal operating Mode of the DL2000. In this mode the Channels are now configured as they are defined by the configuration and the DL2000 Model. The DL2000 is ready to interface your equipment.

The Reset pushbutton automatically puts the DL2000 into Online mode.

4.2 Offline Mode

Once the Configure Pushbutton is pressed the Offline OFF-LINE FLASH Manager is started. Using either the configuration software and the “**DL Offline Manager**” option or a Windows Hyper Terminal type program with com port settings of 9600 Baud, 8,N,1 and Xon/Xoff flow control.

DL OFF-LINE FLASH MANAGER Version 1.21 - 00/06/07

(c) Equus Technologies Inc. 1999-2000

MAIN MENU FUNCTIONS

1 - Restore EEPROM to Factory settings

2 - WRITE new Firmware Text file

3 - Memory DUMP

4 - OFF-LINE Diagnostic Tests

5 - DEBUG Mode

6 - Display FIRMWARE Version

7 - Go ONLINE

MAKE SELECTION (1-7) -

4.3 OFF-LINE Flash Manager Options

1. Restore EEPROM to factory settings
Once pressed you will be asked “**Restore EEPROM to defaults (Y/N)?**” If the answer is “Y”es then the Online parameters will be reset to defaults of Address 1, and settings of 9600,N,8,1 on the CHB (Port B) and SDLC 57.6K on the CHA (Port A-DH+/RIO).
2. Write New Firmware
Once pressed the message “**THIS OVERWRITES DATALINK FIRMWARE!! PROCEED (Y/N)**” will be displayed. Hit “Y” and the next message will appear telling you that it is alright to send the new firmware to the Flash;
ERASING FLASH, PLEASE WAIT...

SEND FIRMWARE TEXT FILE NOW...

Once the message to send the firmware appears then either click on the “Burn Flash System File” button to select the .txt file to send, or send the Text File under HyperTerminal.
Wait for a “**FIRMWARE LOAD/BURN COMPLETED A-OK!**” message to appear.
3. Memory Dump
This is used to display the RAM memory of the DL2000. This should only be done after contacting Equustek Solutions to debug problems.
4. Off-Line Diagnostics
Starts a series of tests to test the DL2000’s hardware and should only be done if instructed so by trained personnel.
5. Debug Mode
Starts up a DL2000 internal Debug mode that can be used by trained personnel to debug problems and check hardware configuration and operation.
6. Display Firmware Version
Once selected the current DL2000 model and version numbers will be displayed. Can be used to check the correct firmware was burnt into the Flash or if the DL2000 has the most up to date firmware in the Flash.
7. Go Online
Does a soft “software” reset of the unit to put it online.

5.0 Switch and LED Indicator Functions

5.1 Switch Functions

The Reset pushbutton will perform a complete hardware reset of the DL2000. It is identical to a complete power cycle and will cause the DL2000 to go through its LED start-up sequence as defined in Section 2.3.

The Configure pushbutton takes the DL2000 out of On-Line operation mode and puts it in the OFF-LINE Flash Manager mode. The OFF-LINE FLASH Manager mode also allows for configuration parameters to be downloaded from or uploaded to the Windows based configuration software (DL32-FREEstanding). When this mode has been entered the ERR and CHAN 2 OUT LED's will be on. To put the unit back On-line it is necessary to either press the Reset or cycle the power supplied to the DL2000.

5.2 Indicator Functions

5.2.1 Power-Up and Reset Sequence

On Power-up or after the Reset button has been pressed the DL2000 executes a self diagnostic check-up of the ram and flash firmware. The correct LED indicator sequence to show the DL2000 is functioning properly is as follows: After all LEDs go out.

LED	STATUS
PWR	Green Continuously
ERR	Green for 0.5 seconds
CHAN 2 OUT	Green for 0.5 seconds
CHAN 2 IN	Green for 0.5 seconds
CHAN 1 OUT	Green for 0.5 seconds
CHAN 1 IN	Green for 0.5 seconds

After this sequence the DL2000 goes into the On-line mode of Operation. The LED indicators will behave in the certain way defined by the DL2000 model used. Most likely all LEDs will be off except the CHAN 1 IN LED will be on indicating the unit is on a valid DH+ or RIO network.

5.2.2 Normal On-line Operation

The following is a description of the normal operation of the Channel Leds on the DL2000. Custom products operation will differ than the following:

LED	Description of Operation
PWR	Green Indicates Power is being supplied to the DL2000.
CHAN 1 IN	On when a specific message is directed to PORT A.
CHAN 1 OUT	On when a specific message is directed out PORT A.
CHAN 2 IN	On when a specific message is directed to CHB (Port B or B').
CHAN 2 OUT	On when a specific message is directed out CHB (Port B or B').
ERR	Flashes RED for about 0.5 secs when a NAK (Negative Acknowledgement) is received on CHB or all transmit and receive buffers are full. Will also flash at approximately 1Hz when a duplicate DH+ node is detected.

5.2.3 On-Line, Power-Up and Reset Errors

The following table describes the meaning of LED patterns if the internal diagnostic tests detect an error on Reset/Power-Up.

LED Pattern	Description of Problem
ALL LED's Flashing ON & OFF	The flash has not be burnt properly and the A-OK was not transmitted. Please reburn the flash with the correct text file. Contact Customer Support for help.
ALL LED's ON Solid	The OFF-LINE FLASH has been corrupted. A new Flash Chip has to be supplied by the factory. Please contact Customer support.
Start-up Sequence keeps repeating.	The DL2000 EEPROM is corrupt.. Please Restore to Factory Settings (See Section 1.1) and then reconfigure the unit.

5.2.4 Off-Line Modes

The following table describes the meaning of LED patterns in the different Off-Line modes of operation.

LED Pattern	Description of Operation
CHAN 2 OUT & ERR	OFF-LINE FLASH Manager/Configuration Parameter Download/Upload and Hardware Diagnostics Testing Mode
CHAN 2 IN & CHAN 2 OUT & ERR	Offline Debug Mode

6.0 DL2000 Wiring Diagrams and Jumpers

6.1 Input Voltage Selection

6.1.1 AC Voltage selection

SUPPLY VOLTAGE	JP1	JP2	JP3
110 VAC	X	N.C	X
220 VAC	N.C	X	N.C

Note:

- N.C means Not Connected – X has a 0 Ohm resistor for Model 1 or a 2 prong shunt for Model 2.
- No selection required for 50/60Hz
- 110 VAC cable is supplied with unit and is wired as follows:
Green is Ground, Black is Live (Hot) and White is Neutral.

6.1.2 DC Voltage selection

10 to 35 VDC – Connect directly to DCP (+) and DCN (-)
(JP1, JP2 and JP3 position do not matter)

Note: REMOVE AC Power Cord First

6.2 Port B' Connector (CHB) Internal Jumpers

PIN	RS232		RS422/485	
	SIGNAL	JUMPER	SIGNAL	JUMPER
1	RTSB	W13 1-2	RxDB+	W13 2-3
2	CTSB	W12 1-2	RxDB-	W12 2-3
3	RxDB	W10 1-2	RxDB+	W10 2-3
4	Ground			
5	TxDB	W11 1-2	TxDB-	W11 2-3

Note: 5 Pin Connectors are numbered from Left to Right

For two wire RS485 Jumper Pins 1-3 and 2-5 for + and - wires respectively

6.3 Online Cable DL2000-PORT A DH+ (CHA)

DL2000-PORT A DH+

Other DH+ Nodes

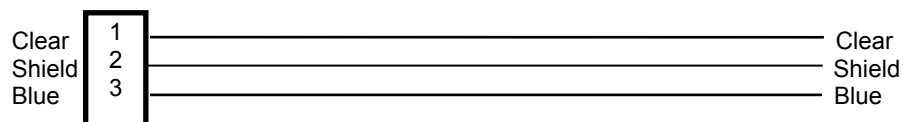

Notes: Pin numbers are 1,2,3 left to right when viewed from the rear
Clear & Blue might have to be swapped depending on existing DH+ wiring

6.4 Configuration Cable/Online Cable DL2000-Port B (CHB) RS-232 – No Handshaking

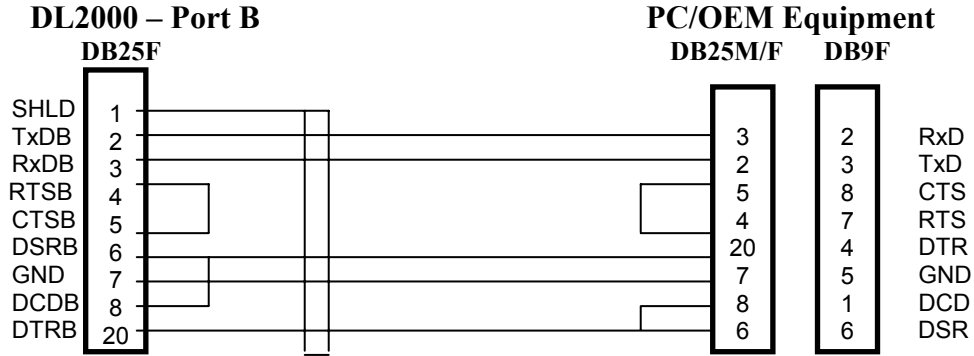

6.5 Online Cable DL2000-Port B (CHB) RS-232C – With Handshaking

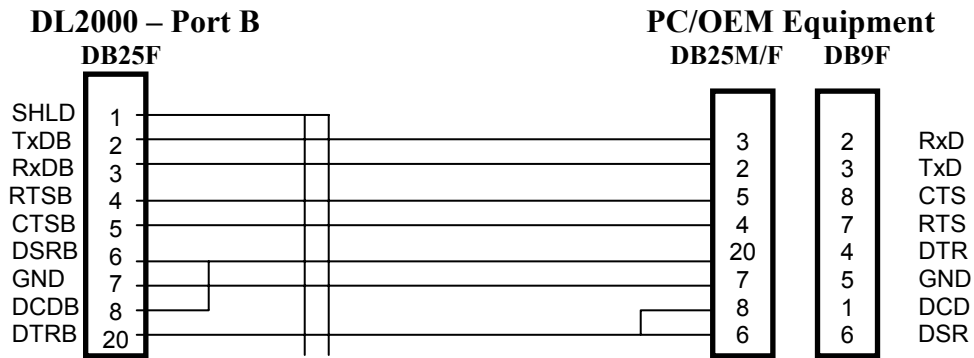

6.6 Online Cable DL2000-Port B (CHB) RS422/RS485

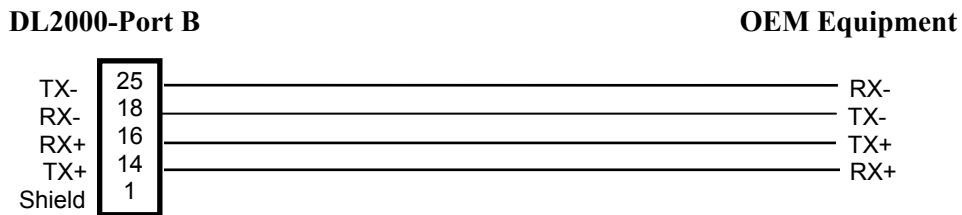

For two wire RS485 Jumper Pins 14-16 and 18-25 for + and - wires respectively

6.7 Online Cable DL2000-Port B (CHC) RS232

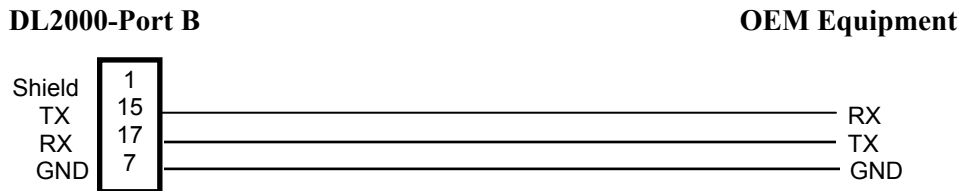

6.8 Online Cable DL2000-Port B (CHC) RS422/RS485

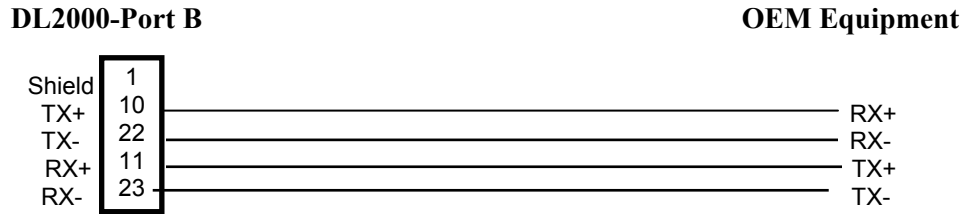

Note: For two wire RS485 Jumper Pins 10-11 and 22-23 for + and - wires respectively

6.9 Online Cable DL2000-Port B' (CHB) RS232

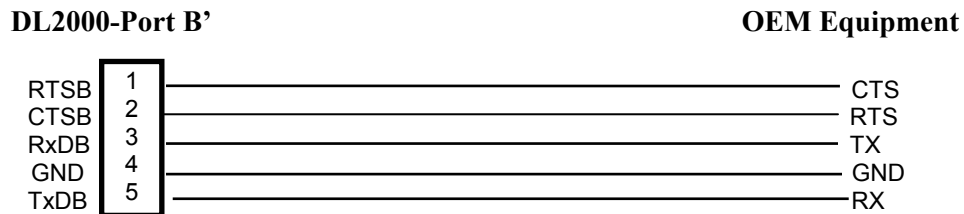

Note: 5 Pin Connectors are numbered from Left to Right

6.10 Online Cable DL2000-Port B' (CHB) RS422/RS485

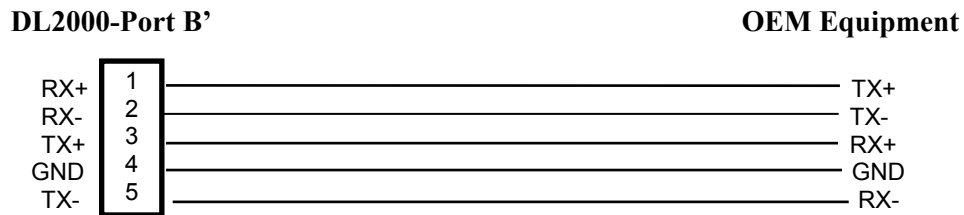

Note: 5 Pin Connectors are numbered from Left to Right

For two wire RS485 Jumper Pins 1-3 and 2-5 for + and - wires respectively

7.0 DL2000 DH+ Networking Applications

7.1 DL2000-CMX – Modbus Master/Slave to interface to DH+

7.1.1 Modbus Master Mode

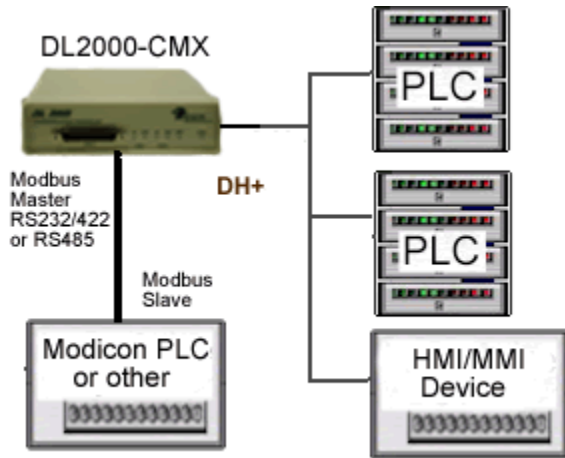

NOTE:

The Modbus Master can communicate with any Slave device on the Modbus Slave network and any DH+ devices capable of sending PLC3 or PLC5 message commands. Modbus and DH+ addresses must not be duplicated (convert to the same radix) or the Master will receive two responses. The DL2000 can be any station number on DH+ including Station 00 (not used on Modbus).

7.1.2 Modbus Master Mode using MODBUS PLUS VIA BM85 BRIDGE

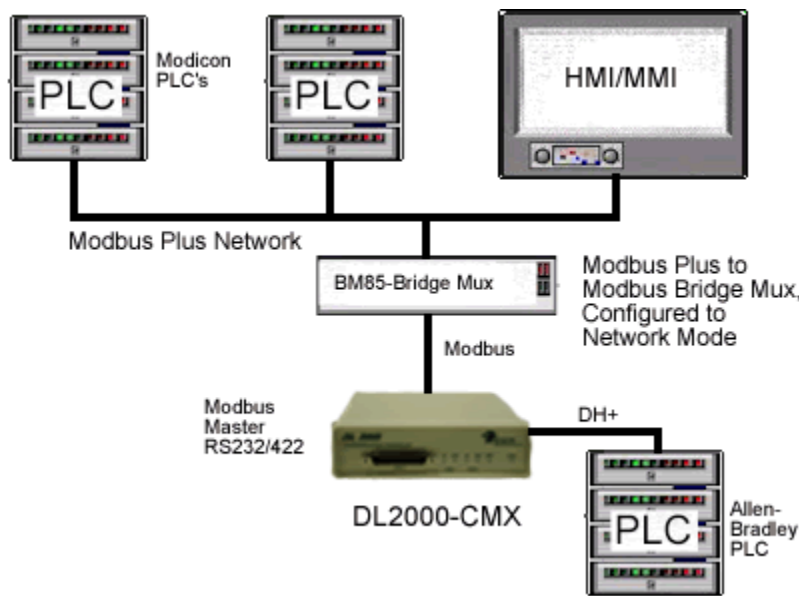

NOTE:

PLCs and HMI/MMIs etc. on Modbus Plus can be programmed to communicate with PLC5s, SLC5/04s and HMI/MMIs on DH+, i.e. any devices capable of handling PLC-5 Type message commands.

7.2 DL2000-KFX – DF1 to DH+ interface

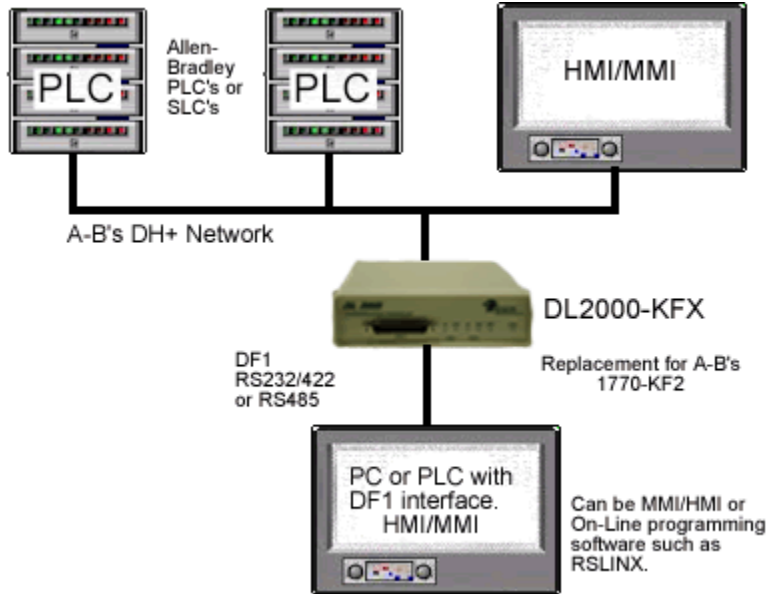

7.3 DL2000-ASM – DH+ to ASCII Scanner/Printer interface

