



DL3500-DH+/MODBUS COMMUNICATION CONTROLLER APPLICATION NOTE

This application note contains information on the DL3500-Modbus to DH+ interface. The DL3500 model contains two modes of operation, Modbus Master and Modbus Slave, which are selectable by the PC Configuration Software. The latest version is available on the web at <http://www.equustek.com/downloads.html>. The information contained in this application note is supplementary information specific to Modbus not contained in the regular User's Guide.

Master or Slave mode?

This application note is divided into two parts, Modbus Master and Modbus Slave modes; they correspond to the mode the DL3500 is going to be on the Modbus Network, and which side either DH+ or Modbus the commands will be initiated on.

Master mode is used when a device on the DH+ network is going to initiate all communications with one or many Modbus slave devices. **Please Refer to DL3500-DH+/Modbus Master Application note.**

Slave mode is used when a device on the Modbus network is going to initiate all communications with one or many SLC's, PLC's or other DH+ devices. **Please Refer to DL3500-DH+/Modbus Slave Application note.**

The application notes generally assume that a SLC or other DH+ device which can originate commands to Modbus via a DL3500 in master mode, or responding to Modbus commands via a DL3500 in slave mode. Only devices capable of transmitting DH+ message commands in PLC5 (or PLC3) format and able to receive DH+ message commands in PLC5 format can be used with the DL3500-Modbus/DH+ including SLC's, MicroLogix's, ControlLogix's and HMIs as well as other intelligent devices.

Due to differences between DH+ and Modbus protocols and the universal design of the DL3500 there are differences between the lengths of messages, error handling and addressing which have to be carefully considered by the Systems Designer, Programmer and Installer.

CAUTION:

Incorrect configuration may result in unsafe operation, damage to equipment or safety hazard to personnel.

Read the DL3500 User's Guide and the appropriate application notes carefully before putting a DL3500 on-line.

The hardware and software must be fully tested off-line in a safe "TEST" environment prior to putting the unit on-line in an operational environment.

DL3500-DH+ MODBUS MASTER TO A-B DH+ CONFIGURATION

Use this option when the DL3500 is required to be the master on a Modbus network.

The Modbus Master Application notes contain configuration information for the DL3500-DH+ protocol and should be used in conjunction with the DL3500 User's Guide.

DL3500-DH+ MODBUS SLAVE TO A-B DH+ CONFIGURATION

Use this protocol when the DL3500 is required to be a slave device on a Modbus network.

The Modbus Master Application notes contain configuration information for the DL3500-DH+ protocol and should be used in conjunction with the DL3500 User's Guide.

NOTES:



1. The unit that you have received can be configured as Modbus Master or Modbus Slave.
Ensure that you understand and carefully follow the specific configuration procedures for the Modbus protocol.
2. **There are significant differences between the configuration, programming and operational requirements of the Modbus Master and Modbus Slave protocols.**
3. If you configure the DL3500 for Modbus Master Operation it must be the only master on the Modbus network. A station on DH+ originates commands to the DL3500-DH+ Modbus Master that then re-transmits them over Modbus to a Modbus Slave device. Other intelligent DH+ devices capable of initiating DH+ messages in PLC5 (or PLC3) format and able to receive PLC5 message commands could also be used as the DH+ "master".
4. Be sure to fully test the hardware and software off-line to ensure that you understand its configuration and operation. Prior to putting the DL3500 on-line in an production process, the operation of the complete system should be fully tested on-line in a safe "test" environment.
5. Due to differences between DH+ and Modbus hardware and software, there are differences between the lengths of messages, error handling and addressing which have to be carefully considered by the Systems Designer, Programmer and Installer.
6. Additional literature regarding DH+, Modbus and PLC products can be obtained from Modicon and A-B. Suggested reference materials for A-B DH+ protocol is shown in section 1.7 of the User's Guide.

CAUTION:

Incorrect configuration may result in unsafe operation, damage to equipment or safety hazard to personnel.

Read the DL3500 User's Guide and the appropriate application notes carefully before putting a DL3500 on-line.

The DL3500 hardware and software must be fully tested off-line in a safe "TEST" environment prior to putting the unit on-line in an operational environment.

Contact Technical Support if you need further information or assistance.

TECHNICAL SUPPORT

Tel : (604) 266-8547

Or E-Mail: info@equustek.com

The following table provides a reference between the different radixes used for your reference

DECIMAL TO OCTAL TO HEXADECIMAL ADDRESS CONVERSION TABLE

DEC	OCT	HEX	DEC	OCT	HEX	DEC	OCT	HEX	DEC	OCT	HEX
00	00	00	16	20	10	32	40	20	48	60	30
01	01	01	17	21	11	33	41	21	49	61	31
02	02	02	18	22	12	34	42	22	50	62	32
03	03	03	19	23	13	35	43	23	51	63	33
04	04	04	20	24	14	36	44	24	52	64	34
05	05	05	21	25	15	37	45	25	53	65	35
06	06	06	22	26	16	38	46	26	54	66	36
07	07	07	23	27	17	39	47	27	55	67	37
08	10	08	24	30	18	40	50	28	56	70	38
09	11	09	25	31	19	41	51	29	57	71	39
10	12	0A	26	32	1A	42	52	2A	58	72	3A
11	13	0B	27	33	1B	43	53	2B	59	73	3B
12	14	0C	28	34	1C	44	54	2C	60	74	3C
13	15	0D	29	35	1D	45	55	2D	61	75	3D
14	16	0E	30	36	1E	46	56	2E	62	76	3E
15	17	0F	31	37	1F	47	57	2F	63	77	3F



APPLICATION NOTE

DL3500-DH+/MODBUS SLAVE PROTOCOL

The information contained in this configuration guide is for the Modbus Slave protocol only, and is supplementary to the information in the User's Guide.

INDEX FOR MODBUS SLAVE TO DH+

1.0 GENERAL	2
1.1 MODBUS COMMAND CAPABILITIES	2
1.2 BROADCAST COMMAND	2
1.4 MODBUS EXCEPTION CODE RESPONSES	3
1.5 MODBUS MESSAGE DATA LENGTH CONSIDERATIONS	3
1.6 MODBUS TO DH+ - GENERAL OVERVIEW	3
1.7 MODICON MODBUS TO A-B PLC ADDRESS MAPPING	4
1.7.1 DEFINITION OF MODBUS SLAVE PARAMETER SCREEN	5
1.7.2 MODICON TO AB ADDRESS MAPPING EXAMPLE	5
1.7.3 ADDRESS MAPPING LIMITATIONS AND PRACTICES	6
1.7 MODBUS MASTER USING BM85 MODBUS PLUS/MODBUS BRIDGE MUX	7
2.0 MODBUS APPLICATIONS	8
2.0.1 MODBUS MASTER TO DH+ NETWORK	8
2.0.2 MODBUS PLUS TO DH+ VIA BM85 MODBUS BRIDGE	8

1.0 GENERAL

The DL3500-DH+ Modbus Slave module facilitates communication between a Modbus Master and an Allen-Bradley DH+ network. It provides for serial communications to Modbus with RS232C, RS232 or RS422/RS485 interface capabilities. Interface cable drawings are located in section 3. Communication between Modbus and the DL3500-DH+ can **only** be initiated from a Modbus Master (not from the DH+).

The Modbus serial port on the DL3500-DH+ is transparent to Modbus and does not require an address. The DH+ network side of the DL3500 unit is an active station on the DH+ and requires its own DH+ address that must be different than the DH+ station address(es) that the Modbus Master needs to communicate with.

A Modbus Master can read and write to any SLC on DH+ that can handle PLC5 message commands without the need for any programming in the SLC, however the PLC addresses used must not be "protected" and the full range of addresses that the Modbus Master requires to read from or write to must have been previously created in the SLC's data Table. Modbus read and write bit/coil commands are used with A-B SLC Binary (B) files and Modbus read and write word/register commands are used with A-B SLC's Integer (N) files.

1.1 MODBUS COMMAND CAPABILITIES

The DL3500-DH+ firmware module is compatible with the following Modbus commands: -

DH+ Station #	Modbus Command Code	Modbus Command Description	Modbus Address
1-63	01	Read Coil Status	00001 - 09999
1-63	02	Read Input Status	10001 - 19999
1-63	03	Read Holding Register	40001 - 49999
1-63	04	Read Input Register	30001 - 39999
1-63	05	Force Single Coil	00001 - 09999
1-63	06	Pre-set Single Holding Register	40001 - 49999
1-63	16	Pre-set Multiple Holding Registers	40001 - 49999
00	05,06,16	Broadcast Command	

Note: Modbus command 15 (Force Multiple coils) is not available in slave mode.

1.2 BROADCAST COMMAND

Modbus protocol uses the Broadcast command (i.e. commands 05, 06 and 16 with a station address of 00) to write to all slave devices on a Modbus network simultaneously, no response is expected by the Master. Allen-Bradley DH+ protocol does not support Broadcast. A-B SLC's are not capable of responding to a single "Broadcast" command over the DH+ network. DL3500s can be configured to ignore or to execute Broadcasts. Broadcasting is accomplished by splitting the command into separate messages for retransmission one at a time to each DH+ station within pre-configured range of stations. Because of the time taken to send out multiple messages over the DH+, Broadcasts commands are normally restricted to an absolute minimum range of DH+ stations.

A SLC or other device at DH+ station address 00 cannot be addressed by Modbus read or write commands as 00 is normally the Broadcast command. DH+ station 00 may be used as the DH+ station address for the DL3500.

NOTES:

1. Restrict the DH+ stations receiving a Modbus broadcast to prevent writing to unintended DH+ destinations.
2. Valid Modbus Slave addresses of stations on DH+ are 1 to 77 octal (i.e. Slave station addresses 1 to 63 dec.).

1.3 COMMUNICATIONS SEQUENCE

The DL3500 module receives a Modbus query on its asynchronous serial port, converts it into the appropriate DH+ message and sends it out on the DH+ network. The DH+ response is received, converted into the corresponding Modbus response and sent back to the Modbus Master. Modbus protocol does not allow messages to be buffered so the DL3500 processes one message at a time. The DL3500 unit will respond to the Modbus interface with the appropriate Modbus exception codes in the event of detectable errors.

1.4 MODBUS EXCEPTION CODE RESPONSES

ERROR CODE	GENERAL DESCRIPTION	DESCRIPTION OF MODBUS AND DH+ INTERFACE ERRORS AS APPLICABLE TO THE DL3500-DH+
1	Illegal Function	does not recognise Modbus Function field.
2	Illegal Data Address	Cannot translate the Modbus address to DH+ format. Ensure that the address is in the range 1 - 63 dec.
3	Illegal Data Value	Modbus message is longer than the DH+ can handle.

1.5 MODBUS MESSAGE DATA LENGTH CONSIDERATIONS

The following shows the maximum number of coils/registers that can be sent or received in a single Modbus message. The limits are because of the different structure of Modbus and A-B DH+ protocols, and also due to the internal memory structure of the DL3500. These values have only a limited relationship to the Modbus/DH+ address mapping ranges configured in the DL3500.

- The max. number of coils that can be read in a single transaction is 1600. (Normal Modbus allows 2000)
- The max. number of registers that can be read in a single transaction is 100. (Normal Modbus allows 125)
- The max. number of registers that can be written in a single transaction is 100. (Normal Modbus allows 100)

CAUTIONS:

1. Ensure that your communications program design prevents self-optimising Modbus Master communications programs (in some MMIs and Operator Interfaces) from requesting data in packets larger than the above limits.
2. Ensure that the Modbus program does not generate Modbus commands with addresses that can bridge across more than one of the address range entries configured in the DL3500.
3. Any of the above conditions could cause indeterminate errors.

1.6 MODBUS TO DH+ - GENERAL OVERVIEW

The DL3500 unit is transparent to valid Modbus commands addressed to station numbers corresponding to active stations on DH+. The DL3500 will only accept commands to DH+ station addresses 1 to 63 decimal. Modbus commands using address 0 are broadcast commands and are handled differently by the DL3500.

After formatting and converting the Modbus message to DH+ protocol the command is sent out to the addressed DH+ (slave) device. If the station is inactive the query is disregarded. Each addressed slave station must be a unique address on Modbus and on the DH+ network (i.e. do not duplicate an address used on the Modbus network with a station address on the DH+). If duplicate addresses exist then the situation will arise where two or more stations could accept the query resulting in multiple responses which would cause communications errors and perhaps writing to unintended destinations.

NOTE:

Special consideration should be given to the Modbus and DH+ addressing to avoid duplication of network addresses. Confusion could arise because A-B uses an "octal" addressing scheme for DH+ network stations and Modbus uses "decimal". Ensure use of a common numbering scheme (see section 1.6 for cross-references).

1.7 MODICON MODBUS TO A-B PLC ADDRESS MAPPING

The relationship between Modicon Modbus and Allen-Bradley PLC addresses is programmed by the user and is stored in the DL3500's EEPROM. The DL3500 can be programmed for eight different address ranges. Each Modicon address range that you wish to set-up may be mapped to a unique A-B address range. The length of the A-B field required is the same as that defined by the Modicon address range. All A-B files should be either Binary, Integer or Floating Point files. These A-B files must be created by the A-B PLC programmer to the full length required by the Modbus Address Translation and Mapping parameters specified. No logic is needed in the A-B PLC to respond to commands received from the Modbus network. To define how a range of Modicon addresses maps over to Allen-Bradley addresses, the user must enter the following configuration information:

In the configuration software the type of PLC used is selected. See below.

MODICON START Register	MODICON END Register	A-B START File		Floating Point
XXXXX	XXXXX	FILE	WORD	
40001	40100	7	0	<input type="checkbox"/>
1	100	3	0	<input type="checkbox"/>
				<input type="checkbox"/>
				<input type="checkbox"/>
				<input type="checkbox"/>
				<input type="checkbox"/>
				<input type="checkbox"/>
				<input type="checkbox"/>

Modbus Parameters-DL32 V3.1

1.7.1 DEFINITION OF MODBUS SLAVE PARAMETER SCREEN

- Modicon Start Address: Specifies the starting address of a range of Modbus addresses that will be mapped to A-B. Valid entries are 00000 to 09999, 10000 to 19999, 30001 to 39999 and 40001 to 49999.
- Modicon End Address: Specifies the end address of a range of Modbus addresses that will be converted to A-B. The range of entries is shown above.
- A-B Starting Address: Specifies the A-B PLC starting file number for the Modbus data. Valid entries are 001:000 to 999 : 999 (Sometimes files less than 8 are reserved) (ensure that data length does not exceed file boundary). **NOTE: N7 and B3 are valid files!!**
- Floating Point Checkbox: Used to Specify if the data is Modbus Floating point and to be written into Floating Point Files

Coils/discretes:

The bit address range of an A-B Binary file is 1000 words or 16,000 bits (i.e. 0 - 15,999 decimal). This means that one A-B file is more than sufficient to hold the largest Modbus coil address possible. An A-B binary file/bit address starts at bit 0 and the first “legal” Modbus coil address starts at 1, which means that normally the first Modbus coil address 00001 (or 10001) will correspond to bit 0 in A-B word 0. If a Modbus address of 00000 (or 10000) is entered in the Starting Address field it causes the first (legal) Modbus coil addresses i.e. bit 1 to correspond to an A-B file/word bit 1. This technique makes it easy to compare and match the Modbus and A-B memory maps, and easier to bit search the A-B program. When a Modbus coil /bit address is defined in the Start Address field, i.e. 0XXXX or 1XXXX, then the first A-B Starting Address that can be used is Binary file 3 word 000 (B3:0).

Registers/words:

The word address range of an A-B Integer file is 0 - 999 i.e., only 1000 words (registers). Therefore if a Modbus address range greater than 1000 registers is required, it is necessary to use more than one A-B Integer (N) file, which will require multiple configuration parameter entries. The first A-B address that can be used for 3xxxx and 4xxxx register/word transfers is an A-B Integer file at file/word address N7:0.

Address Ranges:

The Modicon Address Range (i.e., Start Address less End Address), and the A-B Start Address selected, must not overflow the maximum A-B file address limit. This means that if A-B Starting Address of word 250 is used then the maximum register range for mapping must be 1000 minus 250, i.e. 750.

1.7.2 MODICON TO AB ADDRESS MAPPING EXAMPLES

Example 1 Integer Files

Mapping Modicon registers 40001 to 40010 to A-B file N7:0 to N7:9
Mapping Modicon registers 30011 to 30070 to A-B file N12:21 to N12:80

Modicon Start xxxxx	Address Modicon End Address xxxxx	A-B Starting Address (File:Word)
40001	40010	7:0
30011	30070	12:21

Example 2 Binary Files

Mapping Modicon coils 00001 to 00010 to A-B file B3/48 (binary file B3, bit 48) to B3/57
Mapping Modicon coil 00020 to A-B file B3/98
Mapping Modicon coils 10001 to 10010 to A-B file B3/32 to B3/41

Modicon Start xxxxx	Address	Modicon End Address xxxxx	A-B Starting Address (File:Word)
00001		00010	3:3
00018		00020	3:6 NOTE
10001		10010	3:2

NOTE: When mapping a Modicon coil to an A-B PLC bit that does not start at bit 0 of a word, an offset to bit 0 must be added.

Example 3 Floating Point Files

Mapping Modicon registers 40001 to 40002 to A-B file F8:0
Mapping Modicon registers 30001 to 30010 to A-B file F8:5 to F8:9

Modicon Start xxxxx	Address	Modicon End Address xxxxx	A-B Starting Address (File:Word)	Floating Point
40001		40002	8:0	<input checked="" type="checkbox"/>
30001		30010	8:5	<input checked="" type="checkbox"/>

A-B Floating Point (F) values are 32 bits in length and require two Modbus registers for each floating point value.

MAPPING NOTES:

1. The A-B file corresponding to Modbus Coil addresses should have been previously configured in the PLC as a Binary (B) file and its size configured for the largest coil address.
2. The A-B file corresponding to Modbus Register addresses should have been previously configured in the PLC as an Integer (N) file or a Floating Point (F) file and its size configured for the largest register address.
3. Leading zeros are not necessary when using the DL32 “configure /open file”

1.7.3 ADDRESS MAPPING LIMITATIONS AND PRACTICES

Modbus protocol generally permits a maximum of about 125 registers or 2000 coils to be read in a single transaction (the maximum number is dependent on the Modbus driver). When specifying multiple address translation ranges within the same type of Modbus address (either Oxxxx, 1xxxx, 3xxxx or 4xxxx) it is essential to establish a buffer region of at least 125 registers or 2000 coils between each address type’s range. Failure to do this may allow a self-optimising MMI interface program to write (or read) data to/from two different areas of the Allen-Bradley SLC with undesired and indeterminate results.

Below are some examples that define a similar A-B word address to the Modbus start address. Using this technique for mapping allows for easier comparison between the Modbus and A-B addresses. For example a Modbus start address of 40001 can be represented in A-B PLC-5 file format by using A-B integer file N 40:001. Address



mapping using this technique is recommended for a user's convenience only, as it provides a very useful method for record-keeping, cross-reference and recognition. This technique is not mandatory and any Modbus address can be written to any A-B file.

Modicon Start Address xxxxx	Modicon End Address xxxxx	A-B Starting Address (File:Word)
00000	09999	009:000 (Binary File)
10000	19999	010:000 (Binary File)
30001	30999	030:001 (Integer or Floating Point File)
32001	32999	032:001 (Integer or Floating Point File)
40001	40999	040:001 (Integer or Floating Point File)
41250	41999	041:250 (Integer or Floating Point File)

NOTE: The (Binary File) and (Integer or Floating Point File) text after the A-B File:Word address does not appear on the configuration screen and is provided here for reference only.

When considering use of the above technique note that the first available open A-B file address for a PLC-5 controller is file 7. Modbus address 0xxxx cannot be displayed similarly in A-B format as A-B output file 0 can be used, but not recommend for readability. **For reference the Output file is '0' and the Input file is '1'.** In this case for easy recognition use an A-B Binary file for Modbus output coils such as 9, 99, 999 or any other convenient file number is easily recognisable.

DL3500 firmware permits the entry of 00000 and 10000 values in the Modicon Start Address field even though strictly speaking these are not legal Modbus addresses. This feature allows a programmer to align an A-B Binary file bit 1 with the first legal Modbus Bit / Coil address 1. For example mapping Modicon Start Address 00000 to A-B Start Address (B) 003:000, or Modicon Start Address 10000 to A-B Start Address (B) 010:000 aligns Modbus bit 1 with A-B bit 1. The "B" for Binary file is implied but not displayed.

NOTES:

1. Enough space must have been configured and be available in the A-B file to contain the full range of Modbus addresses specified or it will cause over-writing existing A-B files and data.
2. Do not transmit Modbus messages to the DL3500 to read or write more than 1600 coils or 100 registers in a single Modbus read or write command (see section 1.4 above).
3. Ensure that all A-B addresses specified have been created in the destination PLC on DH+.
4. Set all unused Modbus to A-B addresses to zero.

1.7 MODBUS MASTER USING BM85 MODBUS PLUS/MODBUS BRIDGE MUX

The DL3500-DH+ will communicate with Modicon PLCs and other devices via Modbus Plus when it is connected to one of the four Modbus ports of a NW-BM85-000 Modbus Plus/Modbus Network Bridge Mux (see DL3500 users guide for cable drawings)..

If a Modicon PLC (or other device) on Modbus Plus requires to communicate with a single A-B PLC on DH+ then the selected Bridge Mux Port connected to the DL3500 can be configured as **SLAVE** in which case it must have the same Modbus station number as the target PLC-5's station address on DH+.

If a Modicon PLC (or other device) on Modbus Plus requires to communicate with multiple A-B PLCs on DH+ then the selected Bridge/Mux Port connected to the DL3500 should be set for **NETWORK (slave)** in which case the station number routing of the destination A-B PLC must be programmed into the appropriate Modicon PLC Ladder Logic Master Function Blocks (or command string) for the Modbus Plus network.

Ensure that the serial communications parameters for the Bridge Mux Modbus port are the same as the DL3500's.



2.0 MODBUS APPLICATIONS

2.0.1 MODBUS MASTER TO DH+ NETWORK

(HMI / GUI, SCADA Master or OEM equipment)

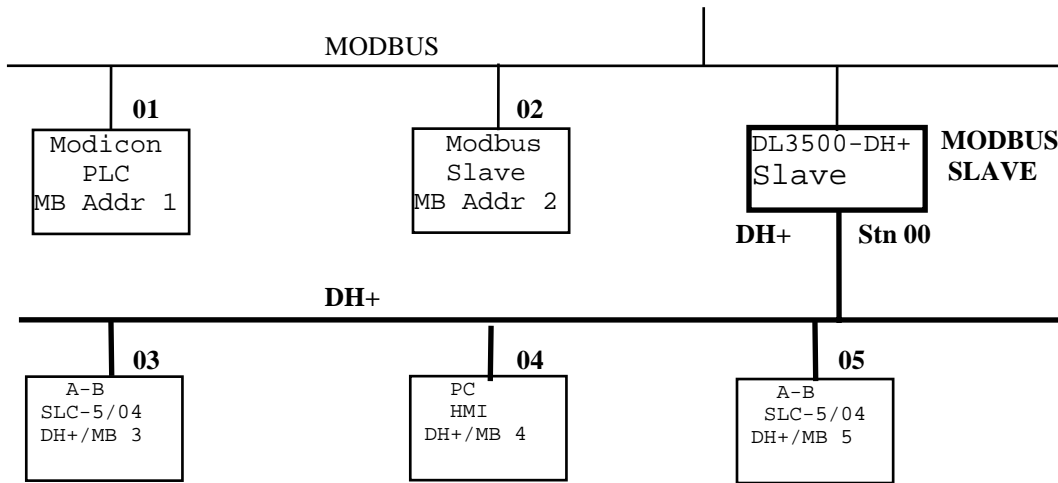

NOTE:

The Modbus Master can communicate with any Slave device on the Modbus Slave network (01 and 02, and any PLC5, SLC5/04 or HMI station on DH+, i.e. devices capable of receiving PLC5 message commands. Modbus and DH+ addresses must not be duplicated (convert to the same radix) or the Master will receive two responses. The DL3500 can be any station number on DH+ including Station 00 (not used on Modbus).

2.0.2 MODBUS PLUS TO DH+ VIA BM85 MODBUS BRIDGE

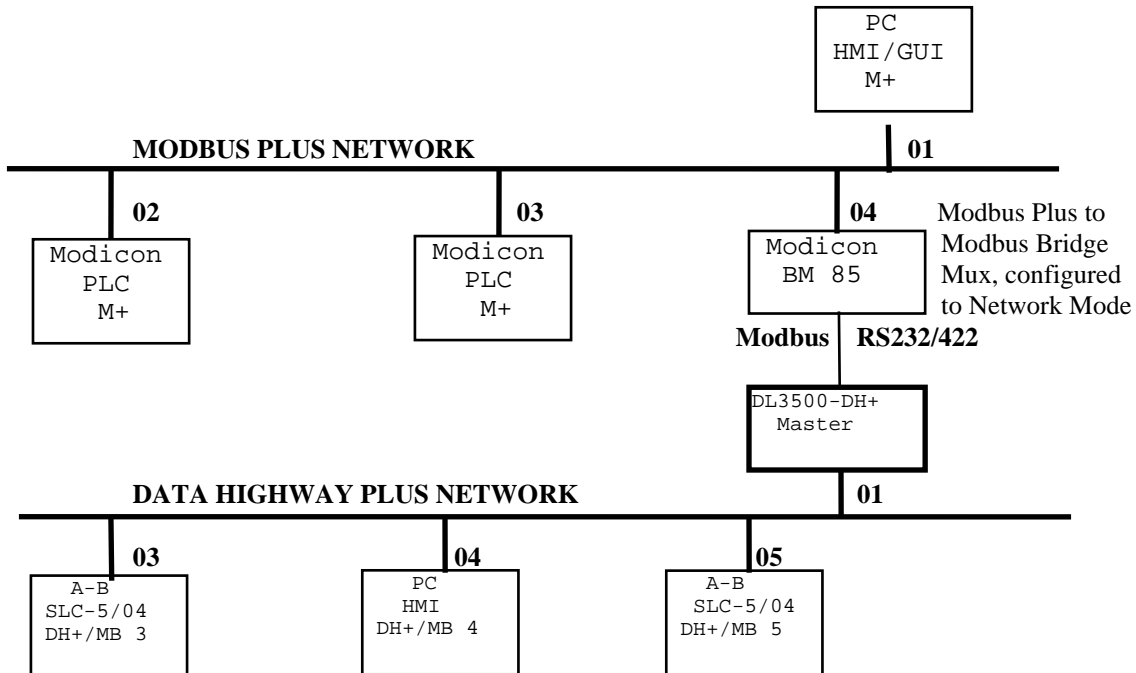

NOTE:

PLCs and HMIs etc. on Modbus Plus can be programmed to communicate with PLC5s, SLC5/04s and HMIs on DH+, i.e. any devices capable of handling PLC-5 DH+ message commands.